

- **INNOVATIVE PRODUCT, BEST IN CLASS TECHNOLOGY**
- ATEX/IECEX/UKCA/INMETRO EXPLOSIONPROOF CAMERA FOR HAZARDOUS LOCATIONS
- AISI316L STAINLESS STEEL CONSTRUCTION
- CERTIFICATION TEMPERATURE -60°C +80°C
- 3MP CAMERA, H.265, 33X AUTOFOCUS OPTICAL ZOOM
- EIS ELECTRONIC IMAGE STABILIZER
- EDGE RECORDING
- OPTIONAL WINDOW WIPER
- IP66/67/68/69, NEMA 4X
- OPTIONAL BUILT-IN FIBER MEDIA CONVERTER
- OPTIONAL BUILT-IN IP OVER COAXIAL CONVERTER
- OPTIONAL BUILT-IN 120VAC OR 230VAC POWER SUPPLY
- H2-READY
- CYBER SECURITY FEATURES
- NDAA COMPLIANT

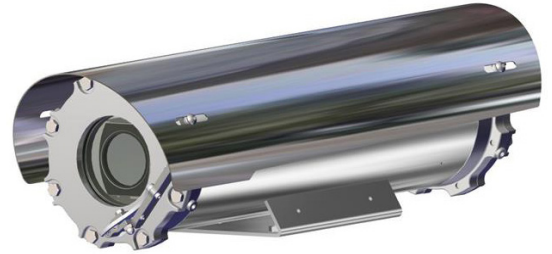

TECHNICAL SPECIFICATIONS

GENERAL & MECHANICAL

Dimensions	See dimensions drawings
Operating Temperature	-60° +60°C, +75°C peak (-76°F +140°F, +167°F peak)
Construction	AISI316L Stainless Steel
Finish	Electro-polished
Mounting	4x M5 on 101,6 PCD 4x M6 on 90x130
Cable entries	2x M25 x1,5
Wiper	Optional
Weight	Unit: 10.5 Kg / Package: 12 Kg (version with wiper)

ELECTRICAL

Temperature Climatization	T[°C] ON = 12 ± 4°C, T[°C] OFF = 20 ± 3°C
Available voltages	24VAC, 120VAC, 230VAC (+/-10%) 24VDC or PoE available on request
Power consumption	40W MAX

CERTIFICATIONS

Ingress Protection	EN 60529 (IP66/IP67/IP68/IP69), NEMA 4X
IK Classification	IK10 on all sides except for the front glass, which is rated IK08
Rating	II 2 G Ex db IIC T6/5/4 Gb -60°C ≤ Tamb ≤ +60/75/80°C II 2 D Ex tb IIIC T85/100/135°C Db -60°C ≤ Tamb ≤ +60/75/80°C
Vibrations and Shock	EN/IEC 60068-2-6; EN/IEC 60068-2-27; DNV-CG-0339
ATEX/UKCA Standards	EN 60079-0; EN 60079-1; EN 60079-31
IECEX Standards	IEC 60079-0; IEC 60079-1; IEC 60079-31
INMETRO	ABNT NBR IEC 60079-0; ABNT NBR IEC 60079-1; ABNT NBR IEC 60079-31
EMC	EN 55032; EN 55035; EN/IEC 61000-3-2; EN/IEC 61000-3-3; EN/IEC 61000-6-2; EN/IEC 61000-6-4; CISPR-32; CISPR-35; DNV-CG-0339

LVD	EN/IEC 62368-1
FCC	FCC part 15B
RoHS	2011/65/EU + 2015/863/EU (RoHS 3)
WEEE	2012/19/EU

VIDEO/CAMERA

Sensor	1/2.8" Progressive CMOS, 3MP
Resolution	- Up to 2065x1553, 3MP (H.264/H.265) - Up to 1920x1080, 2MP (MJPEG)
Compression	H.265/H.264/MJPEG
Streaming	Up to 4 configurable streams
Frame Rate	- 2MP: 60fps (WDR off), 30 fps (WDR on) - 3MP: 30fps (H.264/H.265)
Sensitivity	Color: 0.04 lux, B/W: 0.002 lux
Shutter Speed	1 to 1/10000 s
Optical Filter	Automatically removable IR-cut filter
White Balance	Contrast White Balance
Dynamic range	WDR/HDR
Lens	33x Autofocus Optical Zoom, 10x Digital Zoom, 4.6-152mm, F1.6
FOV	Horizontal: 55° (Wide), 2° (Tele) Vertical: 43° (Wide), 1° (Tele)
Analytics	Motion Detection/Tampering. OPTIONAL: intrusion detection, wrong direction, object removal, sabotage, loitering, stopped vehicle, object counting
Image settings	Color, Brightness, Sharpness, Contrast, White Balance, Exposure control, 2D/3D Noise Reduction
Event Triggers	External Input, Analytics, Network Failure Detection, Periodical Event, Manual Trigger
Event Actions	External Output Activation
Edge Recording	Micro SD/SDHC/SDXC (card not provided)
Network Storage	Support for recording to NAS

INNOVATIVE EXPLOSIONPROOF FIXED CAMERA STATION

SNR	>50dB
Noise Reduction	3D Motion Compensated Noise Reduction
Iris	P-Iris, Auto-Iris
Image Stabilization	EIS

NETWORK

Interface	100BASE-TX or 100BASE-FX/1000BASE-X (fiber)
Security	User Authentication/ HTTPS/ IP Filter/ IEEE 802.1x/SNMPv3
ONVIF	ONVIF profile S/T/G/M
Protocols	IPv4/v6, TCP, UDP, RTP, RTSP, HTTP, HTTPS, ICMP, FTP, SMTP, DHCP, PPPoE, UPnP, IGMP, SNMP, QoS, ARP, NTP

FIBER MEDIA CONVERTER

Interface	100 Base-FX/1000BASE-X
Cabling	Singlemode (9/125 µm) /two fibers/SC connector
Maximum Distance	20km
Wavelength	1310 nm

IP OVER COAXIAL CONVERTER

Interface	10/100 Base-TX over Coaxial Cable
Bandwidth	Up to 95Mbps downlink/uplink
Maximum Distance	1800m
Technology	Broadband over Power Lines (BPL)
Interference Prevention	IEEE 1901-2010 Inter-System Protocol ISP

MODELS

TXF1TV2-IP-M	New Generation Explosionproof FIXED IP camera station 3MP 33x, 24VAC
TXF2TV2-IP-M	New Generation Explosionproof FIXED IP camera station 3MP 33x, 120VAC
TXF3TV2-IP-M	New Generation Explosionproof FIXED IP camera station 3MP 33x, 230VAC
TXF1TV2-SM-M	New Generation Explosionproof FIXED IP camera station 3MP 33x, with SM FO media converter, 24VAC
TXF2TV2-SM-M	New Generation Explosionproof FIXED IP camera station 3MP 33x, with SM FO media converter, 120VAC
TXF3TV2-SM-M	New Generation Explosionproof FIXED IP camera station 3MP 33x, with SM FO media converter, 230VAC
TXF1TV2W-IP-M	New Generation Explosionproof FIXED IP camera station 3MP 33x, wiper, 24VAC
TXF2TV2W-IP-M	New Generation Explosionproof FIXED IP camera station 3MP 33x, wiper, 120VAC
TXF3TV2W-IP-M	New Generation Explosionproof FIXED IP camera station 3MP 33x, wiper, 230VAC
TXF1TV2W-SM-M	New Generation Explosionproof FIXED IP camera station 3MP 33x, wiper and SM FO media converter, 24VAC
TXF2TV2W-SM-M	New Generation Explosionproof FIXED IP camera station 3MP 33x, wiper and SM FO media converter, 120VAC
TXF3TV2W-SM-M	New Generation Explosionproof FIXED IP camera station 3MP 33x, wiper and SM FO media converter, 230VAC

- for IP over COAXIAL converter replace the suffix "IP" with "CX"
 - All the above models include sunshield and heater
 - for PoE option, use number "S", ex. TXF5TV2-

PRE-ASSEMBLED CABLE TAILS

EXACCTF3-A	3 meters armored composite cable tail (power, Ethernet, data) with 2x M25 barrier nickel plated brass glands
EXACCTF3-C	3 meters armored composite cable tail (power, data, fiber optic) with 2x M25 barrier nickel plated brass glands. Fiber termination: SC
EXACCTF5-A	5 meters armored composite cable tail (power, Ethernet, data) with 2x M25 barrier nickel plated brass glands
EXACCTF5-C	5 meters armored composite cable tail (power, data, fiber optic) with 2x M25 barrier nickel plated brass glands. Fiber termination: SC
EXACCTF10-A	10 meters armored composite cable tail (power, Ethernet, data) with 2x M25 barrier nickel plated brass glands
EXACCTF10-C	10 meters armored composite cable tail (power, data, fiber optic) with 2x M25 barrier nickel plated brass glands. Fiber termination: SC

ACCESSORIES

SSBK-M	Wall mounting bracket
SSPM-M	Pole mount adapter for SSBK-M
SSPTM-M	Top pole mount adapter
SSDM-M	Adapter to pair with IR LED illuminator on a single SSBK-M bracket

DIMENSIONS

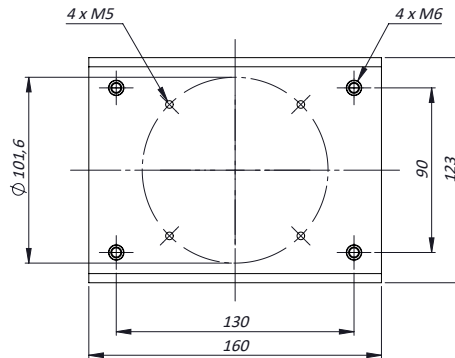
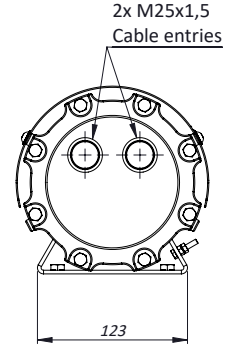
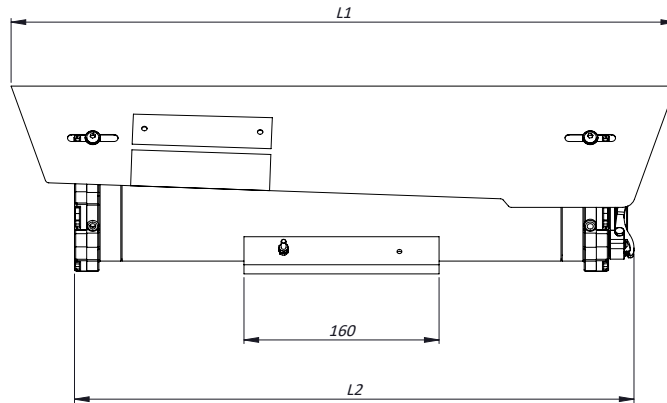
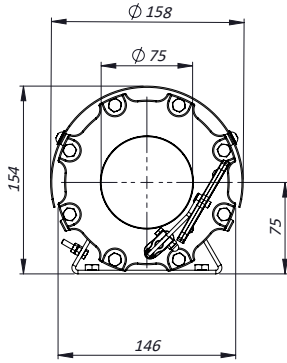

MAX EXTERNAL LENGTH

Model	L1 [mm]	L2 [mm]
TXF1TV2-IP-M	545	460