

Ceiling Mount Bracket CMB for ExCam DEX5000i

Datasheet.

Features.

Compatible

with all cameras of the ExCam DEX5000i Series with the model-key T08.

Data.

Mechanical Characteristics

Material:	Stainless steel
Weight:	12.0 kg
Dimensions:	WxHxD 290x190x220
Point load:	50 kg

Scope of Delivery

- included
- 5 screws M8x12
 - 5 screws M8x16
 - 10 flat washer M8

Dimensions [mm].

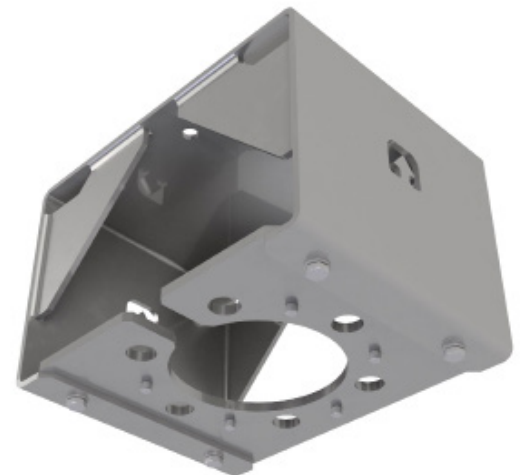
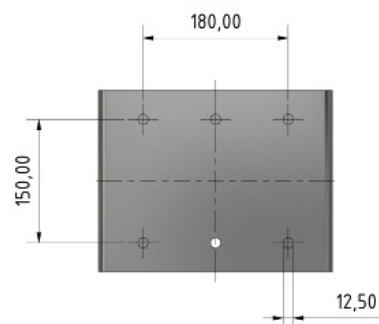
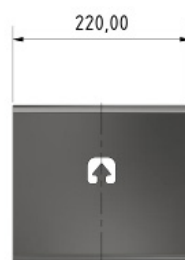
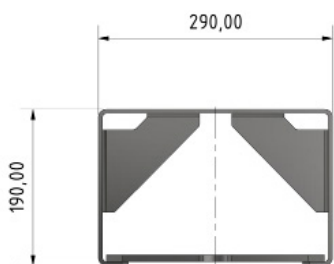

Dexter System Solutions B.V.
Bakkenzuigerstraat 40
1333 HA Almere
Netherlands
info@dexter.eu
T: +31 36 5368216

Dexter System Solutions B.V. all rights and technical changes reserved. No liability for wrong or missing data.